



Original Instructions

Installation Operations and Maintenance manual

STEELCLEAN series

Incorporated in this manual there are the following documents:

- Declaration of conformity
- Technical schedule
- Dimensional drawing
- Wiring diagrams



Reproduction, data storage and transmission, even partial, of this publication, in any form, without the prior written authorisation of the Company, is prohibited. The Company can be contacted for all inquiries regarding the use of its products.

The Company follows a policy of continuous product development and improvement and reserves the right to modify specifications, equipment and instructions regarding use and maintenance at any time, without notice.

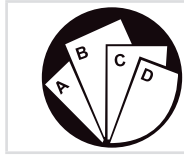

Multiple instructions:
Consult the specific part



Read and understand
the instructions before
undertaking any work on
the unit

Declaration of conformity

We declare under our own responsibility that the below equipment complies in all parts with the CEE and EN directives. The declaration of conformity is enclosed to the technical schedule enclosed with the unit.

This unit has been designed in accordance with the following EU Directives:

- **Directive 2006/42/CE** of the European Parliament and of the Council of 17 May 2006 on machinery;
- **Directive 2014/30/EU** of the European Parliament and of the Council of 26 February 2014 on the harmonisation of the laws of the Member States relating to electromagnetic compatibility (recast);
- **Directive 2004/35/EU** of the European Parliament and of the Council of 26 February 2014 on the harmonisation of the laws of the Member States relating to the making available on the market of electrical equipment designed for use within certain voltage limits (recast), and complies with "essential criteria for safety and health protection" therein specified.

Unit is therefore equipped with appropriate devices fully described in the technical literature supplied with the unit. Installer should carefully connect and activate all safety components provided on the unit and check for their operation.

The plant or system, where this unit is assembled in, must similarly comply with EU Directives mentioned above.

End users, or any plant operators, should periodically check for proper operation and efficiency of safety devices.

Non activating or removing or impeding operation of active safety devices, as well as removal of passive safety equipment, will cause immediate loss of the Company liability with regard to any accidents or damages, direct or indirect, to persons or property, due to the Company manufactured unit.

The Unit manual, provided with the unit, is completed by a TECHNICAL SCHEDULE reporting all essential unit construction and operational data together with relevant DRAWINGS.

Upon unit delivery, the Company issues a "CONFORMITY DECLARATION" related to UE Directives and a description of "potential hazard condition" and precautions adopted during construction to prevent these risks.

Transportation and handling, as well as operation of unit, should be carried out in accordance with instructions given in the present notes and following pages, as well as technical literature supplied with the unit.

Guarantee is limited by conditions and terms described in the "WARRANTY CERTIFICATE" supplied with the unit and bearing unit type and serial number.

Servizio di assistenza svolto da Vortice Industrial s.r.l.
e-mail: info@vorticeindustrial.com

GENERAL INDEX

1. INTRODUCTION	06
1.1 Preliminary information	06
1.2 Aim and content of the manual	06
1.3 How to store this manual	06
1.4 Manual update	06
1.5 How to use this manual	06
1.6 Potential risks	07
1.7 General description of symbols used	08
1.8 Safety symbols used	09
1.9 Limitations and prohibited use	10
1.10 Unit identification	10
2. SAFETY	11
2.1 Safety integration principles	11
2.2 Instructions for worker's safety	11
2.3 Check at receipt	11
3. TRASPORTATION AND HANDLING	12
3.1 Receipt and inspection	12
3.2 Lifting and handling	12
3.3 Storage	13
3.4 Unpacking	13
3.5 Personal protective equipment	13
4. INSTALLATION	14
4.1 Preliminary notice	14
4.2 Service area requirements	16
4.3 Section coupling and bolting	16
4.4 Coil connections	18
4.4.1 Water coils	18
4.4.2 Steam coils	18
4.4.3 Direct expansion coils	19
4.5 Hydronic connections	19
4.6 Air connections	20
4.7 Electrical connections	20
4.7.1 Plug-fan / Brushless fan connections	20
4.7.2 Safety devices on doors	21
4.7.3 Internal unit lighting	21
4.7.4 Unit ground connection	21
5. UNIT START UP	22
5.1 Preliminary checks	22
5.1.1 Checks before start-up	22
5.1.2 Checks during unit operation	22
5.2 Safety system	22
5.3 Electric motors, fans	22
5.4 Air filters	23
5.5 Coils	23
5.6 Dampers	24
6. MAINTENANCE	24
6.1 Safety system	24
6.2 Fans EC Brushless	25
6.2.1 Fans maintenance	25
6.2.2 Cleaning and safety test	25
6.3 Air filters	26
6.4 Coils	26
6.5 Dampers	26
6.6 Unit shut down precautions	27
6.7 Summary schedule for periodical maintenance	27

6.8	Trouble shooting	28
6.9	Unit record book	29
7.	UNIT CLEANING	30
8.	REPLACEMENT PARTS	32
8.1	Unit identification	32
8.2	Identification of the part to be replaced	32
8.3	Replacement parts ordering	32
9.	DISMANTLEMENT, MATERIALS' DISPOSAL AND RECYCLING	32
9.1	Unit disconnection	32
9.2	RAEE Directive (only UE)	33
10.	INDICATIVE POSITIONING OF ADHESIVE SIGNALING AND NAME PLATE OF IDENTIFICATION	34

1. INTRODUCTION

Air handling units should be installed and operated in accordance with requirements listed in this manual. Observing these simple instructions carefully is a preliminary precaution in order to:

- totally avoid or substantially decrease number of unit shutdowns for unforeseen breakdowns;
- increase component efficiency and consequently conserve energy;
- increase component and unit life;
- decrease maintenance need and costs.

1.1 Preliminary information

The present manual is realized to allow the correct unit's installation, the start up and maintenance.

The unit to which these instructions refer, has been designed for the uses that will be presented in the appropriate paragraphs and must only be used for which it has been expressly sized (see TECHNICAL SCHEDULE), compatibly with its performance characteristics.

The Company will not be liable for claims for damage caused to persons, animals, material goods or property caused by improper installation, adjustment and maintenance or improper use. Any other use not specified in this manual is prohibited and doesn't imply any commitment or constraint for the manufacturer.

This document is intended to provide information only and does not form a contract with third parties.

The Company pursues a policy of constant improvement and development of its products and therefore reserves the right to change the specifications and the documentation at any time, without notice and without obligation to update existing equipment.

1.2 Aim and content of the manual

These instructions are intended to provide the information required for the selection, installation, use and maintenance of the unit.

They have been prepared in accordance with the European Union laws and with the technical standards in force at the date of issue of the instructions. Observe the local safety regulations in force at the time of installation.

The instructions contain all the necessary information to prevent any reasonably foreseeable misuse.

1.3 How to store this manual

The manual must be kept in a suitable place with easy access for users and operators, protected from dust, damp and and easily accessible to users and operators for any further consultation.

The manual must always accompany the unit during the entire life cycle of the same and therefore must be transferred to any subsequent user.

1.4 Manual update

It is recommended that the manual is updated to the latest revision available.

If updates are sent to the customer they must be added to this manual.

The latest information regarding the use of its products is available by contacting the Company.

1.5 How to use this manual



The manual is an integral part of the unit.



Users or operators must consult the manual before performing any operation and especially so when transporting, handling, installing, maintaining, or dismantling the unit in order to eliminate uncertainty and reduce risk.

In these instructions symbols have been used (described in the following paragraphs) to draw the attention of operators and users to the operations that have a higher risk and which must be performed safely.

1.6 Potential risks

Any operation which can produce dangerous situations is indicated in this manual. It also contains precautionary measures for any specific case.



CAUTION !

Any operation which can produce dangerous situations is indicated in this manual. It also contains precautionary measures for any specific case.

- All the units are provided with pictograms with danger warnings.
- All the units are safe, and it is forbidden to tamper with the machines or to remove security protections.
- To operate in total secure conditions it is helpful to have a technical preparation, and it is important to respect the proceedings illustrated in this manual and eventual signallings affixed in critical places of the unit.
- The following dispositions must be respected during the installation, the start up, the use and maintenance of the unit:



- Do not start up the unit before its electric components are wired to the building's electric plant;
- Do not start up the unit before the fan outlet is wired to a duct or protected with an accident prevention grid;
- Do not use the unit as a support for another machine;
- Do not use the unit as a platform;
- Do not use the unit as an equipment's storehouse;
- Do not open inspection doors while the fan is working, especially near pressure sections;
- Do not leave inspection doors half closed, but check that handles and knobs are completely closed;
- Do not expose oneself to ultraviolet lamp's light, which are situated in those sections where germicidal lamps are used.



- Wear individual security devices before working with the unit;



- Before unit's start up check that all electrical devices are off. Especially, before opening inspection doors, check that the fan is switched off and that no one can start it up without the knowledge of the technician who is operating on the machine;



- Always reassemble the protection grid of the fan section before the start up;



- Pay attention during lifting the machine, because its barycentre can be very unbalanced;
- Pay attention to lifting cables/hooks blocking;
- Pay attention to edges inside the unit;
- Pay attention to roof edges outside the unit;
- Pay attention to possible burns that heat coils can cause;
- Pay attention to possible burns that humidification system can cause;
- Pay attention to servo-controlled dampers which could suddenly close.

Whilst the unit has been designed to minimize any risk posed to the safety of people who will interact with it, it has not been technically possible to eliminate completely the causes of risk. It is therefore necessary to refer to the requirements and symbolism below:

LOCATION OF RISK (if present)	POTENTIAL RISK	METHOD OF INJURY	PRECAUTIONS AND PROTECTIONS
Mixing box with dampers and actuators	Crush	Contact	Remove voltage before any operation
Thermal heat exchangers	Small stab wounds, burns	Contact	Avoid any contact, use protective gloves
Fan and fan grids	Wounds, eye damage, broken bones	Insertion of sharp objects through the grid while the fans are operating	Never put objects through the protection grids
External to unit: unit enclosure	Intoxication, severe burns	Fire due to short circuit or overheating of the supply cable external to unit	Size cables and mains protection system in accordance with iee regulations
Internal component: electric cables and metallic parts	Electrocution, severe burns	Defect in the supply cable insulation, live metallic parts	Adequate protection of power cables, ensure correct earthing of all metal parts

1.7 General description of symbols used

Safety symbols combined in accordance with ISO 3864-2:



BANNED

A black symbol inside a red circle with a red diagonal indicates an action that should not be performed.



WARNING

A black graphic symbol added to a yellow triangle with black edges indicates danger.



ACTION REQUIRED

A white symbol inserted in a blue circle indicates an action that must be done to avoid a risk.

Safety symbols combined in accordance with ISO 3864-2:



The graphic symbol “warning” is qualified with additional safety information (text or other symbols).

1.8 Safety symbols used



GENERAL RISK

Observe all signs placed next to the pictogram.

The failure to follow directions may create a risk situation that may be injurious to the operators and users.



ELECTRICAL HAZARD

Observe all signs placed next to the pictogram.

The symbol indicates components of the unit and actions described in this manual that could create an electrical hazard.



MOVING PARTS

The symbol indicates those moving parts of the unit that could create risk.



SHARP SURFACES

The symbol indicates components or parts that could cause stab wounds.



EARTH CONNECTION

The symbol identifies Earthing connection points in the unit.



READ AND UNDERSTAND THE INSTRUCTIONS

Read and understand the instructions of the machine before any operations.



RECOVER OR RECYCLE MATERIAL

1.9 Limitations and prohibited use

The machine is designed and built exclusively for the uses described in this technical manual. Any other use is prohibited because it may pose a potential risk to the health of operators and users.



The unit is not suitable for operations in environments:

- excessively dusty or potentially explosive atmospheres;
- where there are vibrations;
- where there are electromagnetic fields;
- where there are aggressive atmospheres.

1.10 Unit identification

Each unit has a name plate, usually mounted on the external side of the unit, that provides key information regarding the machine and main technical characteristics.

The rating plate may differ from the one shown below as the example is for a standard unit without accessories.

For all electrical information not provided on the label, refer to the wiring diagram.

Verify that the characteristics of the electric network comply with the data shown on the identification plate.

A facsimile of the label is shown below on Fig. 1 with the legend of the data included.

VORTICE			
INDUSTRIAL			
Unità tipo / Unit model	<input type="text"/>		2
N° Serie / Serial number	<input type="text"/>		3
Portata aria / Air flow	m ³ /h <input type="text"/>		4
Pressione statica utile / External static pressure	Pa <input type="text"/>		5
Massa / Weight	kg <input type="text"/>		6
Potenza installata / Motor rating	kW <input type="text"/> + <input type="text"/>		7
Corrente assorbita / Full load current	FLA A <input type="text"/> + <input type="text"/>		8
Alimentazione / Power supply	V / PH / Hz <input type="text"/>		9
	<input type="text"/>		
	<input type="text"/>		

Via B. Brugnotti, 3 - 37063 ISOLA DELLA SCALA - Verona (Italy) Tel. +39-045 6631042 - Fax +39-045 6631039

LEGEND:

- (1) CE Mark.
- (2) Unit type and size.
- (3) Serial number.
- (4) Air flow, at standard conditions and external available static pressure.
- (5) External available static pressure.
- (6) Unit's total weight .
- (7) Nominal power input, inductive plus resistive.
- (8) FLA, full load current according to power input type.
- (9) Main supply characteristics, up to three different data for electric components with different supply characteristics.

The "TECHNICAL SCHEDULE" provided with the unit included all other technical details. When corresponding with Vortice Industrial, unit type and serial number (point 2 and 3) must always be indicated.



The product label should never be removed from the unit.

2. SAFETY

2.1 Safety integration principles

The machine is designed and built to avoid any risk for health and people. Many project's solutions have been carried out to avoid (where is possible) any kind of danger.

Where there is no possibility to completely prevent or avoid dangers, please respect behavioural disposition indicated in the paragraph 1.6 "RESIDUAL RISKS" of this manual.



THIS UNIT IS NOT SUITABLE FOR OPERATION IN EXPLOSIVE ATMOSPHERE OR AGGRESSIVE ATMOSPHERE !!

2.2 Instructions for worker's safety

- All the operations (discharge, assembly, moving etc.) must be effected after reading the following instructions. It is also important to respect Safety Directive's prescriptions and individual safety devices.
- Installation and machine's start up must be effected by a qualified staff.
- Deactivate the appliance in case of failure or malfunction.

2.3 Check at receival

Air handling units are shipped without packing and, frequently, divided into different modular sections to be assembled on site. It is recommended to check that sections are divided in the same way as indicated on unit assembly drawings and components are free from damages due to trasportation.

The sections, upon their arrival on site, have a packaging that protects from dirt and atmospheric agents, but not from any impact.

Particularly it should be carefully checked that:

- fan-motor group rotates freely;
- antivibration isolators are not damaged;
- coil fins and threaded pipes are not damaged;
- dampers move freely;
- filters are correctly assembled and not damaged;
- external panels have no scratches or dents;
- no foreign matters are in the unit sections and their internal wall are clean.



Some types of filter cells, e.g. the absolute, bag or activated carbon types, can be shipped in a separate packing. Any damages or lack of material should be immediately reported to the shipping agent and the Company should be informed accordingly.



In case unit sections are stored outdoors before unit assembly, they must be adequately protected against possible damages due to rain or foreign matters or dirt.

3. TRASPORTATION AND HANDLING

3.1 Receipt and inspection

of the labels on the unit, and to take any possible precautions of the case. Not observing the rules reported on this manual can create dangerous situations. After receiving the unit, immediately check its integrity. The unit left the factory in perfect conditions; any eventual damage must be questioned to the carrier and recorded on the Delivery Note before it is signed. The company must be informed, within 8 days, of the extent of the damage. The Customer should prepare a written statement of any severe damage.

Before accepting the unit check:

- The unit did not suffer any damage during transport;
- The delivered goods are conforming to what shown in the delivery note.

In case of damage or abnormalities:

- List the damage on the delivery note;
- Inform the Company of the extent of the damage within 8 days of receipt of the goods. After this time any claim will not be considered.
- A full written report is required for cases of severe damage.

3.2 Lifting and handling

Each unit section or single piece unit is provided with appropriate lifting points (lifting lugs or perimeter holes for lifting bars) clearly identified in the structural base.

When unloading the unit, it is strongly recommended that sudden movements are avoided in order to protect the internal component of the unit.

Lifting procedure to be followed in order to avoid any damages to side panels is schematically shown on Fig. 2; in smaller units, equipped with feet, it is possible to proceed with the handling by means of forklifts, see Fig. 3.

It is important to keep the unit horizontal during the handling and lifting, avoiding absolutely to flip or tilt the sections.

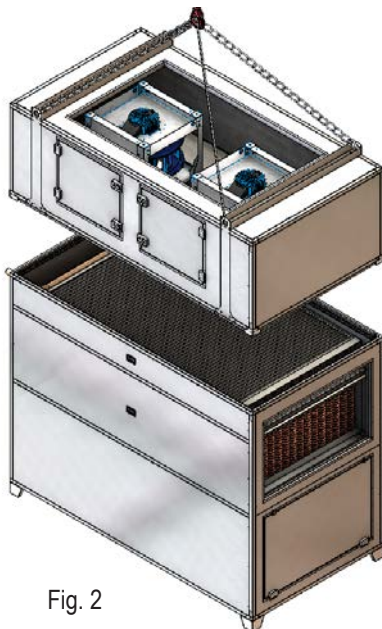

Fig. 2

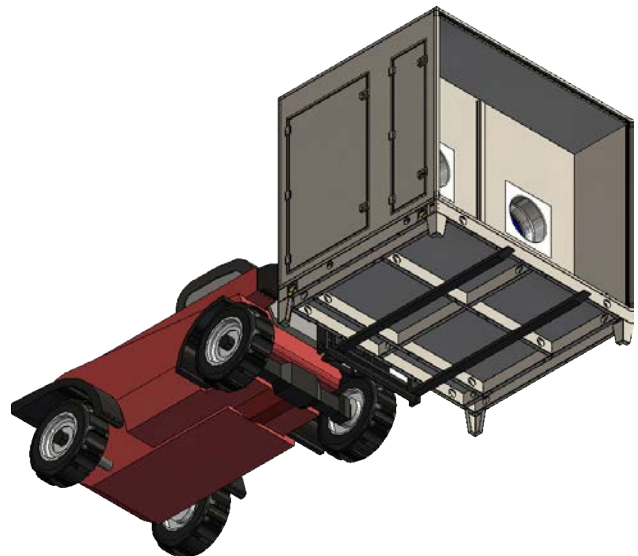

Fig. 3

Unit sections should be handled separately, before any assembly or coupling is made. After sections are assembled, it is NOT possible to move the whole resulting unit.



Weight of each section or unit module, as well as the unit total weight, are shown in the technical documentation supplied with the unit (DRAWING and TECHNICAL SCHEDULE attached).

3.3 Storage

Unit should be stored under cover and ideally, should remain in their packaging. If for some reason the unit was already unpacked, follow these instructions to prevent damage, corrosion and /or deterioration:

- Make sure that all the openings are well closed or sealed;
- To clean the unit, never use steam or other detergents that could damage it;
- The tools that are supplied for opening the electric box (if present) should be formally transferred to the person responsible of the plant.

3.4 Unpacking



Packaging (stretch film for packaging, polystyrene etc.) could be dangerous and must be kept out of reach of children.

It is advisable to leave packaged units during handling and remove it before the installation.
The packaging must be removed carefully to prevent any possible damage to the machine.
The materials constituting the packaging may be different in nature (wood, cardboard, nylon, etc.).
We recommend to remove the protective film from the panels after installing the AHU.



The packaging materials should be separated and sent for disposal or possible recycling to specialist waste companies in order to reduce environmental pollution.

3.5 Dispositivi di protezione individuali



When operating and maintaining the unit, use the following personal protective equipment listed below as required by law.



Protective footwear.



Eye protection.



Protective gloves.



Hearing protection.

4. INSTALLATION

4.1 Preliminary notice

The AHU must be placed in a special area that can be made inside a technical room or outside in a covered area or not, depending on the structure on site.

Prior to proceeding to AHU installation it is recommended to check the following:

- the structure (concrete or other) supporting the unit must be adequately designed for the unit static and operating weight; water mass forecasted in unit sumps must also be considered; supporting base should have an horizontal surface, flat and regular;
- The installation position must minimize the risks in the event of an earthquake or strong winds;
- Electric supply lines must be adequately sized according to the unit electric characteristics.

The positioning area for the unit can be obtained:

- directly on the floor (Fig. A)
- on a special concrete pedestal (Fig. B)
- on a pedestal in metal profiles (Fig. C)
- on a hanging structure in metal profiles (Fig. D)

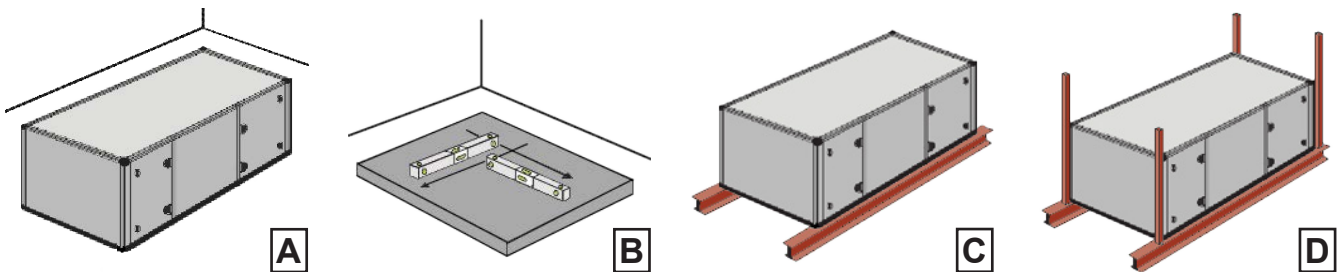

In any case the following minimum requirements must be respected:

- The floor or pedestals must have suitable characteristics to support the mass of the unit in compliance with the required safety limits;
- The contact surface with the lower base frame of the unit must be sufficiently smooth and hard in relation to the mass of the machine;
- The floor or pedestals must allow the construction of siphons on the discharges with the provided hydraulic components;
- The horizontality of the support surface must be checked and any corrections can be obtained using metal shims.

Special precautions must be taken in case of unit supplied splitted into sections and /or large dimensions where it's not envisaged the creation of a positioning place with a single and continuous surface:

- as well as at the begin and end of the unit, points of support must be made in correspondance with any intermediate junctions between individual sections (detectable by the drawing of the machine and /or checked with our Technical Department) (Fig. E (concrete) - Fig. E1 (IPE beams));

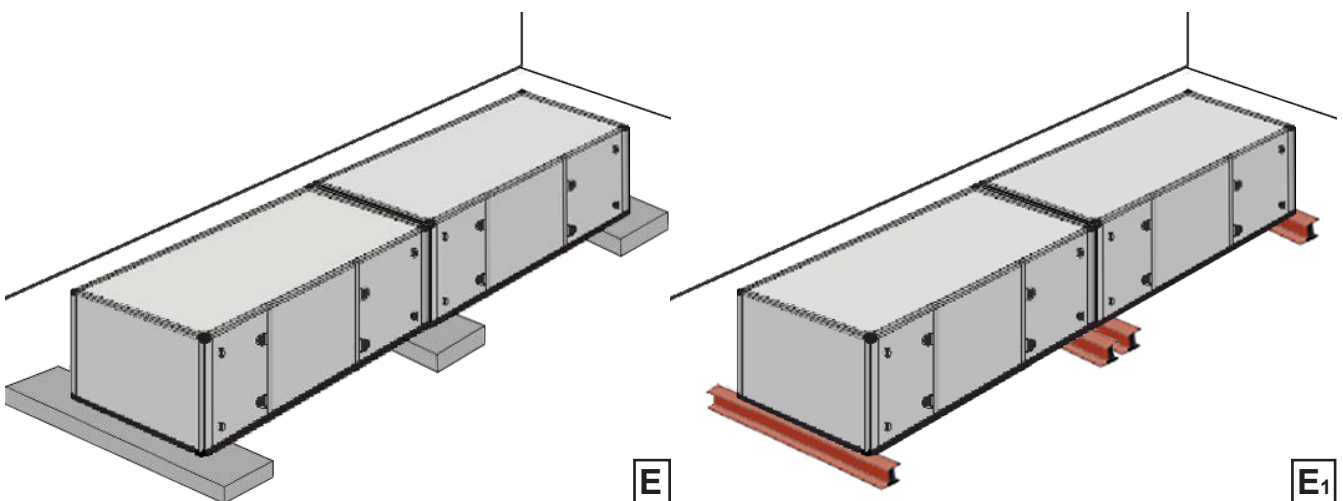

- in case of overhead positioning, the individual support points must be realized in order to support the corresponding mass of the section in consideration of the unit's height and in compliance with the safety limits for seismic risk. (Fig. F (concrete) – Fig. F1 (structure in metal profiles));

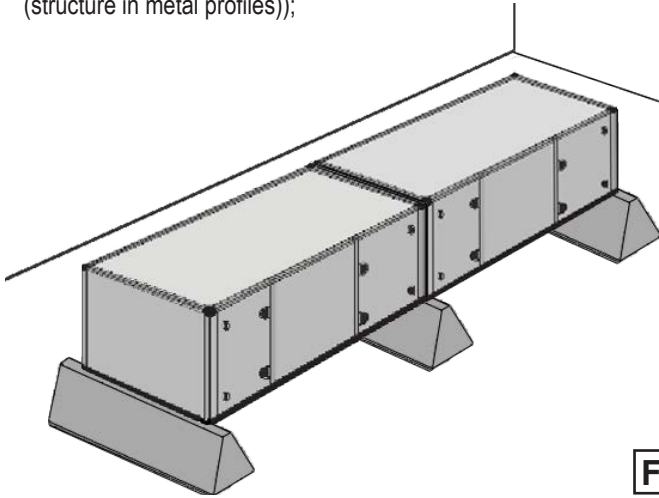

F

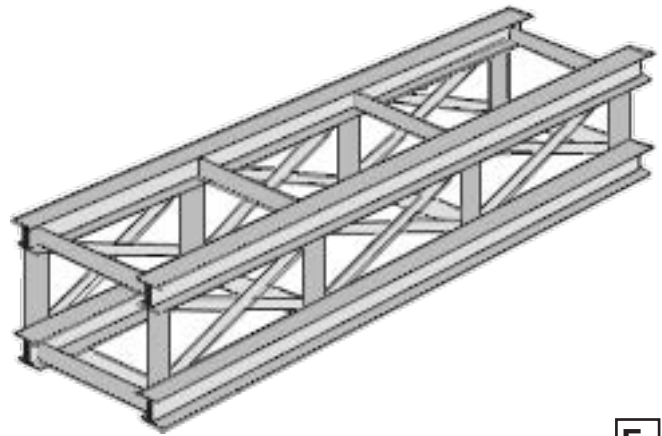

F1

- the surface of the support points must have a suitable width to allow positioning /approaching and assembly operations of the individual sections during the installation phase (Fig. G);
- the contact surface with the base frame must be sufficiently hard and smooth to allow positioning /approaching and assembly operations in relation to the mass of the unit;
- the overall planarity of all the individual support points must be checked and if necessary corrected using metal shims.

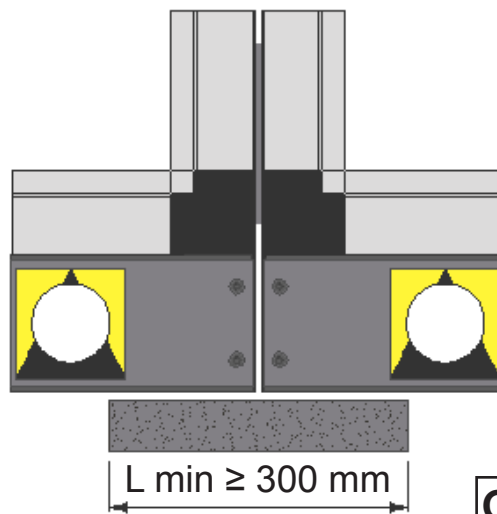

G



READ AND UNDERSTAND THE INSTRUCTIONS

Before undertaking any task the operator must be fully trained in the operation of the machines to be used and their controls. They must also have read and be fully conversant with all operating instructions.



All maintenance must be performed by TRAINED personnel and be in accordance with all national and local regulations.



The installation and maintenance of the unit must comply with the local regulations in force at the time of the installation.

4.2 Service area requirements

Area chosen for unit assembly must allow sufficient clearance space, around and on top of unit, for unit installation and further ordinary and extraordinary maintenance operations.

Particularly important is the service area on the inspection and connection side, in order to allow panels to open completely and coils to slide out completely for extraordinary maintenance.

Fig. 4 shows minimum clearances requested.

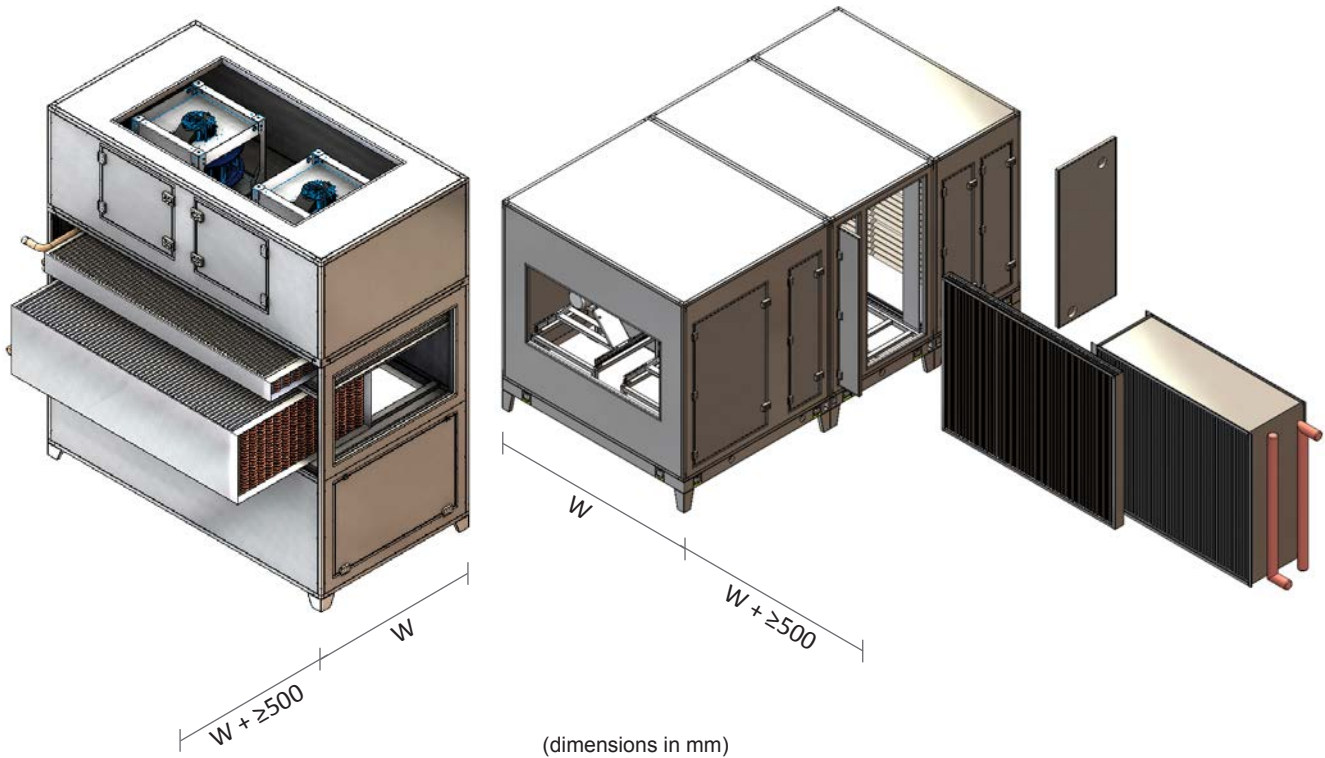

Fig. 4



The unit has to be installed such that maintenance and repair is possible. The warranty does not cover costs for the provision of lifting apparatus, platforms or other lifting systems required to perform repairs during warranty period.

4.3 Section coupling and bolting

For unit delivered in separate sections, it is necessary to proceed to the total assembly on site, according to the overall drawings provided with the unit.

1. Apply supplied self adhesive gasket along the perimetrical face of one of the sections to be coupled. (see Fig. 5)
2. Position first the heaviest section, then set beside the second one and embed it in the provided corner mortises. (see Fig. 5)
3. Bolt sections together by means of holes provided in the profiles and using M8 bolts supplied with the unit.
Fasten gradually and alternatively along the full perimeter until gasket between profiles is fully and uniformly pressed (see Fig. 6).

The coupling of sections can be internal by fixing internal angles, or external by fixing special junctions;
In some cases it may be necessary to partially remove the coils and/or droplet eliminator to access to the junction plates.

4. Apply the sealing cord, supplied with unit, on the two sides and on top of the union perimeter.

EXTERNAL JUNCTIONS SCHEME

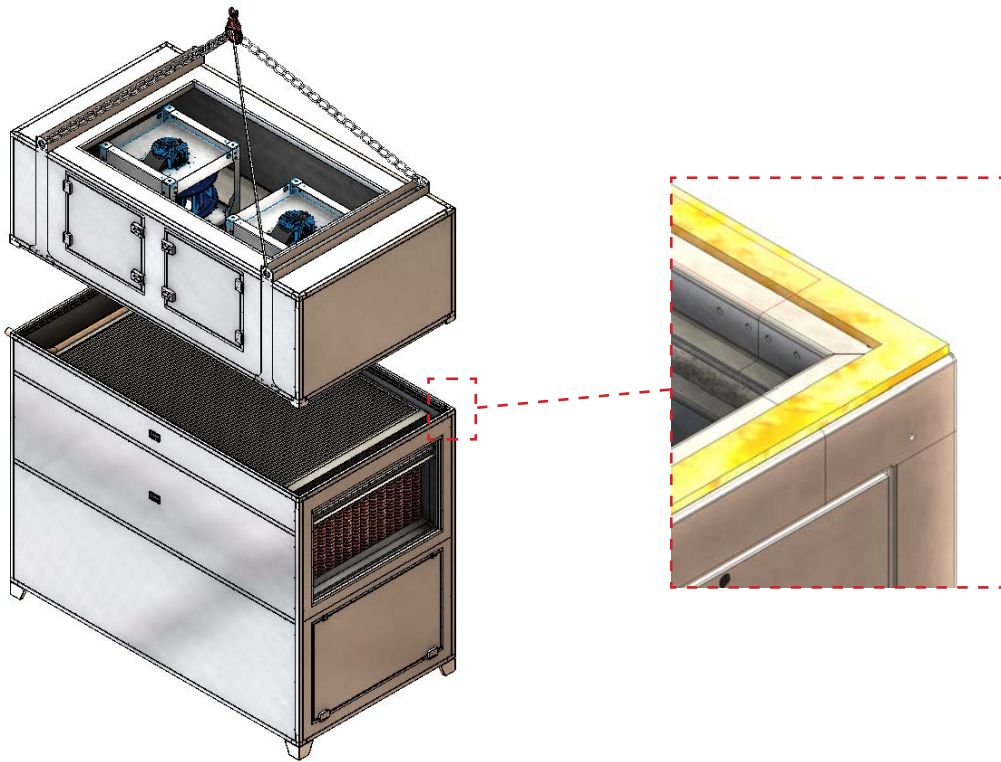

Fig. 5

INTERNAL JUNCTIONS SCHEME

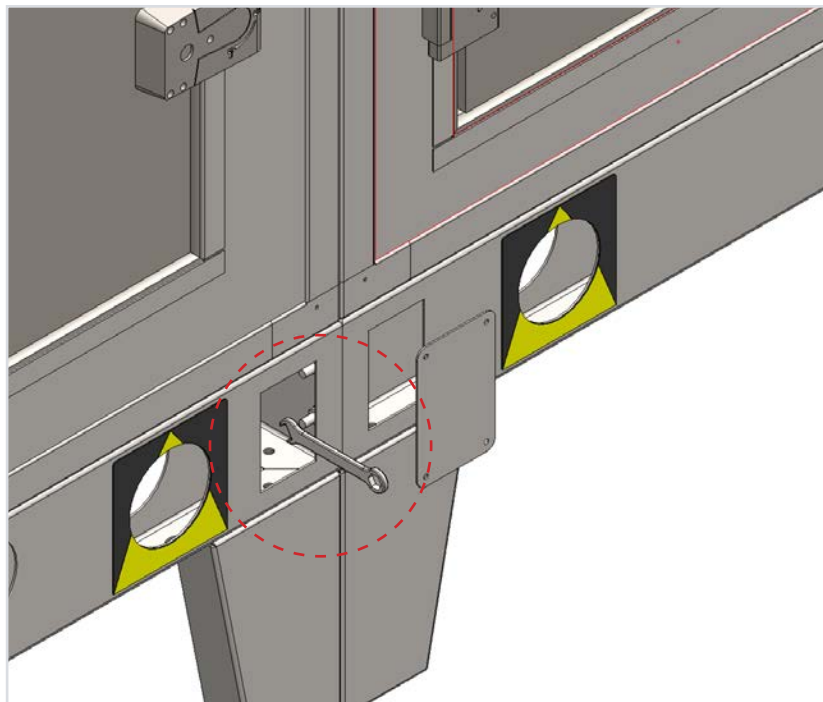

Fig. 6

4.4 Coil connections

4.4.1 Water coils

The following requirements for water connections are also applicable for coils with other fluid, such as glycole solutions, diathermal oil, etc. The following minimal requirements are recommended for any type of installations.

- a) Provide adequate supports for external circuit and thermal expansion joints with vibration isolators; avoid to load coil connections.
- b) Position water pipes and water circuit devices not to impede coil slide out, inspection panel openings and access to any unit sections.
- c) Avoid damages to coil connection solderings by fastening mechanical connections with care without applying any torsions to the same especially when the exchangers are small.



Coil performance is normally rated for counter-flow circuit arrangement, consequently coils are provided with water inlet at the bottom and downstream air flow, outlet at the top and upstream air flow. This rule is ensured by following the applied plates indicating "*Water in*" and "*Water out*".

Furthermore, water circuit should be provided with:

- 1) water drain to be positioned at the unit lowest point (obligatory);
- 2) vent valve at the circuit highest point to allow easy replenishment (recommended);
- 3) shut-off valves, on water inlet and outlet, to allow coil disassembly for extraordinary maintenance;
- 4) for hot water coils, water pump electric interlock with the fan cycling device or circuit bypass, to avoid damages resulting from overheated stagnating air, during fan shutdown periods.

Installer must obviously guarantee the requested value of water flow.

4.4.2 Steam coils

For steam coils, follow same instructions given for water coils at points a), b), and c) of paragraph 4.4.1, paying attention to "*Steam inlet*" and "*Steam outlet*" plates.

When realizing the steam circuit, installer should also take into consideration that:

- 1) steam coils are mounted in the section with an appropriate slope toward the outlet connection, this in order to facilitate a natural drainage of condensate;
- 2) shut-off valves must be installed at steam inlet and outlet, to allow easy disassembly of coil, if necessary;
- 3) condensate should never build up inside coils headers or supply and discharge pipes; adequate slope of minimum 2% toward the boiler should be provided for this purpose, in order to avoid water hammer at steam jet supply;
- 4) condensate from upsteam pipes should never flow through the coil; for this purpose a condensate drain valve should be provided at coil inlet, to be connected to the return pipe to boiler;
- 5) condensate in the coil should be discharged through a condensate drain valve positioned downstream coil;
- 6) in case a steam regulating valve of "on-off" type is installed and the air system can intake air at 0° C or less, it is recommended to provide a steam pressure not less than 0.4 kg/cm², in order to prevent coil from freezing up;
- 7) similarly to water coils, it is recommended to shut off steam supply when fan stops, in order to avoid overheated air from stagnating inside unit, this can damage motors and bearings and impair honeycomb packages.

4.4.3 Direct expansion coils

Instructions given at points a) and b) of paragraph 4.4.1. for water coils should be followed also in this case, bearing in mind that the best coil performance is always obtained with the counter-flow arrangement. In this case coil supply is evidently the one provided with the distribution header where the liquid line must be connected.

The refrigerant circuit must be made in accordance to the best state-of-the-art practice; in any case, the following recommendations are to be followed:

- 1) coil is supplied with a holding charge of refrigerant or dehydrated nitrogen;
- 2) only refrigeration copper tubes should be used, tubes must be thoroughly cleaned, dehydrated and sealed until their use;
- 3) coil distributor should be cut only immediately before proceeding to brazing, which must be carried out in dehydrated nitrogen atmosphere which must be forced inside tube to prevent undesired oxidation;
- 4) same criteria described in point 3) must be used when brazing liquid line to distributor;
- 5) refrigerant circuit must include appropriate controls and devices to guarantee proper system operation, coil is only a part of the system.



When sizing refrigerant circuit make sure that gas velocity is never lower than 2.5 m/s in the horizontal lines and 5 m/s in the vertical risers, this to guarantee oil return to compressor.

4.5 Hydronic connections

All connections should be made with the best available current workmanship practice according to the indicated dimensions of inlet and outlet diameters.

Outlet connections should be complete with water traps and their height calculated on the basis of the maximum negative pressure existing at the drainage point.

A simplified method is to assume this value equal to the total fan pressure and calculate trap dimension as indicated at Fig. 7.

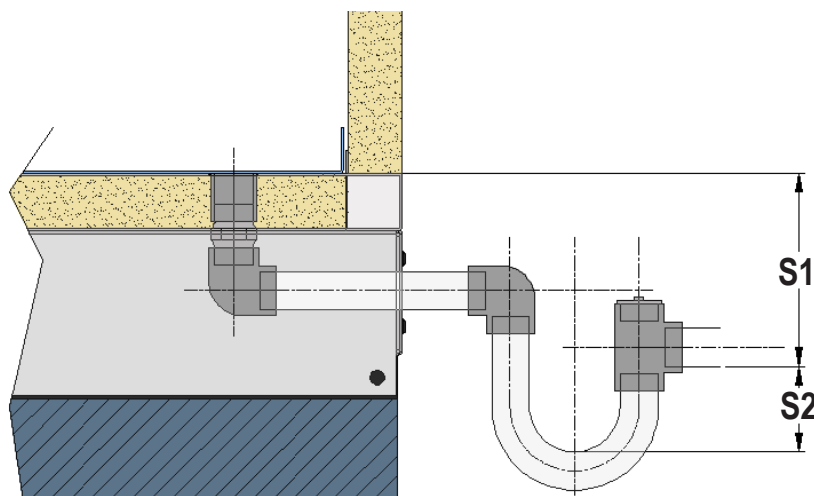

$$S1 = Ht / 10 + 35$$

$$S2 = Ht / 10 \times 0,75$$

S1 - S2 = minimum height, mm, as indicated

Ht = total fan pressure, Pa, as indicated in the "TECHNICAL SCHEDULE"

4.6 Air connections

Air flow connections, to supply, suction and possible exhaust-recycle ductworks, should be made with flanges of the same dimensions of those existing on the central station unit and indicated on the general DRAWING supplied.

4.7 Electrical connections

The unit name plate (Fig. 1) and the literature supplied with the unit show the electric characteristics and the maximum full-load current input (FLA) of all electric motors.

Different main supplies, voltage and phases, can be needed for different uses, for this reason check carefully data on documentation and on the name plate.



The plant should have safety devices conform, for every motor, according to nominal current input.

For the cables connection always use appropriate holes provided on the unit's panel complete of suitable cable gland for cable passageway in the most suitable points.

4.7.1 Plug-fan / Brushless fan connections

Power connections: from the electrical distribution / control panel, connect to the terminal board located on the brushless motor. The cable section is determined by referring to the following table.

Motor Power (three-phase)	Cable type	Cable section	Cable capacity (A)	Motor Current (A) to 400V	Voltage drop L cable = 15 m
0,75 kW	FG16OR16	4G1,5	13,65	1,3	0,09%
1,1 kW	FG16OR16	4G1,5	13,65	1,9	0,13%
1,5 kW	FG16OR16	4G1,5	13,65	2,6 / 3	0,18%
2,2 kW	FG16OR16	4G1,5	13,65	4,1 / 5	0,27%
3 kW	FG16OR16	4G2,5	18,2	5,1 / 6	0,22%
4 kW	FG16OR16	4G2,5	18,2	7,1 / 8	0,29%
5,5 kW	FG16OR16	4G4	24	9,5 / 10,5	0,25%
7,5 kW	FG16OR16	4G4	24	12,7 / 14	0,34%
11 kW	FG16OR16	4G6	30,8	18 / 20	0,34%
15 kW	FG16OR16	4G10	42	26 / 30	0,27%
18,5 kW	FG16OR16	4G16	56	32 / 35	0,24%
22 kW	FG16OR16	4G16	56	38 / 42	0,25%
30 kW	FG16OR16	4G25	73,5	52 / 55	0,23%
37 kW	FG16OR16	4G25	73,5	63 / 66	0,28%
45 kW	FG16OR16	3x35+1G25	90	76,5 / 80	0,24%
55 kW	FG16OR16	3x50+1G25 with 3 circuits adjacent	108	94 / 97	0,22%
55 kW	FG16OR16	3x35+1G25 with only 1 circuit	128	94 / 97	0,30%
75 kW	FG16OR16	3x50+1G25 with only 1 circuit	175	128 / 132	0,30%
75 kW	FG16OR16	3x70+1G35 with 3 circuits adjacent	155,5	128 / 132	0,30%

In case of a three-phase motor, connect the cable to terminals L1, L2, L3, while in case of a single-phase motor, connect the cable to terminals L, N. Connect the yellow-green protective conductor to the PE terminal. In case where on the terminal board there are two terminals marked PE, it is advisable to make a bridge between the two and then connect them to the protective conductor present in the power cable.

This type of motors, report outside the intervention of internal thermal protections.

The status of the thermal protections is available by connecting a shielded cable to the NC and COM terminals. The signaling is made through a NO/NC contact through which it can be interfaced with a possible process controller.

To change the fan speed, connect an external signal to the GND, +10V, 0-10V or Ain 1U terminals. If the signal comes from a PLC, then an analog signal, make the connection between the GND and 0-10V terminals (Ain 1U), if instead the speed regulation is made using a 0-10V potentiometer, connect to the GND, 0-10V(Ain 1U), +10V terminals.

Also in this case a shielded cable must be used.



For detailed technical data, refer to the manufacturer's Data Sheet or to the relative terminal board shown to the attached wiring diagram.

4.7.2 Safety devices on doors

In the event that a door of the unit is opened where motors / fans are installed, the unit must immediately stop.

Fan sections are equipped with a microswitch and/or a protection grid an inlet doors. In presence of a N.O. microswitch, connect it through an auxiliary contact in the circuit breaker; in this way as you open the fan door, it turns off anyway.

All safety microswitches must be connected in series to the "NO" contact, from these, act on a support relay whose contact will be connected to a digital input of the PLC that will be used.

In the event that there wasn't a controller but an electromechanical system, act directly on the opening coil of the general switch that supplies this unit.

Wiring and connections of safety devices to the general safety system of the plant must be done at the installer care according to the note described at the chapter "INTRODUCTION".

Safety devices should be "**interlocked**" according to CEI-EN 60204-1.

When a microswitch operates (or any other kind of electric protection) it must completely and irreversibly inhibit machine's working.

Its restart must be allowed only manually, with an interruption and a following supply restart from the electric panel.

Connection of safety microswitches on fan's doors via FROR cable with 2x1mmq section.

4.7.3 Internal unit lighting

Unit internal lamps should be cabled at installer's care directly on the lighting points provided on the unit. Lighting operation should comply with EU standards and in particular should include an automatic switch-on operation at the moment of any safety devices intervention.

4.7.4 Unit ground connection

Unit ground connection should be made using the appropriate terminals provided outside the unit, with cables of adequate section and carefully following all procedures and standards. Grounding of the unit is fundamental requirement to comply with safety codes against electrical accidents.



Lack, or inadequate grounding relieves manufacturer from electrical accidents liability.



Installer is liable by law for the proper activation of safety devices installed in accordance to EU Directives. All cables and connections of electric parts should comply with the current IEC standards, or the standard national requirements of the country.

5. UNIT START UP

5.1 Preliminary checks

Before starting the unit, it is necessary to carry out preliminary checks.



Start-up operations must be performed in accordance with the instructions detailed in the previous paragraphs.



Malfunctions or damage can occur due to lack of adequate care during shipment, transport or installation. It is recommended that a detailed check is made, before the installation / start up of the unit, that there are no damaged components or parts caused by tampering, vibration during transport or general mistreatment suffered by the unit on site.

5.1.1 Checks before start-up

- Check that the unit is installed in a workmanlike manner and in accordance with the guidelines in this manual.
- Check that all power cables are properly connected and all terminals are correctly fixed.
- Check that the operating voltage is the one shown on the unit labels.
- Check that the unit is connected to the system earth.
- Check that no foreign matters or dirt should be left close to rotating parts (fan impellers) or in other unit sections.
- Check that all drains should be free.
- Check that hydronic circuits should be regularly fed.
- Check that coil circuits should be fed and valves open.
- Check that all access doors or inspection panels are closed with the provided closing systems.



Do NOT modify internal wiring of the unit as this will immediately invalidate the warranty.

5.1.2 Checks during unit operation

- Check that the air flow rates are correct.
- Check the electrical absorption of the machine.



Do NOT approach or insert any objects into moving parts.

5.2 Safety system

Safety systems operation and reliability must be verified by specifically checking their actual intervention on emergency conditions and ensuring that moving parts are effectively stopped; unit shall be de-energized as soon as safety devices show their proper effect. Tests of safety systems must be repeated at least three times for each safety device, and should not be subsequent on the same system. For unit with internal lighting, shut off due to any emergencies must cause immediate lighting of the internal lamps.

5.3 Electric motors / fans

- a) Check for the correct rotating direction of fans, which must be the one shown on the fan housing by an arrow; wrong rotation can be corrected by switching motor electric connections on the three-phase line.

- b) Verify the actual current input and compare this value with data indicated on the unit name plate; in case actual current input is higher, it is necessary to check that:
- fan rotates freely by hand;
 - fan speed is the prescribed one;
 - air volume is not higher than the one indicated on the name plate;
 - electric supply is correct.
- c) Ensure also that all protective guards on rotating parts are held in strong position.

5.4 Air filters

Check that filters have not been damaged during transportation and/or installation and that are free from dirt or other foreign matters. If filters cells have been shipped separately, proceed to their assembly on unit, ensuring that:

- flat filters, extended surface or metallic types, are properly inserted in their guides and that each cell is tight to the next, a slight pressure on the closing panel will ensure this detail;
- bag type filters are properly tighten to frames by means of their springs;
- absolute filter cells are properly mounted and their sealing gasket is tight and held in correct position by slightly fastening screws of the supporting frames;
- differential pressostats, if any, operate properly and are regularly connected.



For other filter types, particular instructions are given, when applicable.

5.5 Coils

Check that fin packs are not damaged and are clean; in case of any bends or flattening of fins for previous mishandling, use fin calibrated combs and restore proper fin conditions and spacing. Coil circuit should be vented repeatedly with pumps in operation.

In case the unit is expected to intake air at temperature below 0° C during cold seasons or that can be held idle in freezing ambient temperature, it is mandatory that all water circuit not in use be completely drained in order to avoid ruptures due to freezing.

To avoid this risk, antifreezing solutions, such as water glycol, can also be used, with adequate component percentages related to the minimum temperature that could be reached in the area.

An informative table is given, showing solution percentages according to various minimal temperatures; in any case it is recommended that tables supplied by glycol producer be followed.

Glycol % in the solution (by volume)	Freezing point °C
0 %	0 °
10 %	- 5,5 °
20 %	- 9,0 °
30 %	- 15 °
40 %	- 25 °
50 %	- 33 °



IMPORTANT:

It should be noticed that, when using a water-glycol solution, coil performance decreases. In these cases a certain penalization should be accepted, unless such operating conditions can be taken into consideration during unit design and heat exchangers sized accordingly, to compensate for the capacity loss.

5.6 Dampers

For manually operated dampers, check that operation is smooth and it is possible to block damper in the desired position easily and efficiently. For motorized dampers ensure there are no slowdowns or stopping in the damper movement along the entire sector. Instructions on electric connections are given by the control manufacturer and supplied with unit.

6. MAINTENANCE

Maintenance can:

- Keep the equipment operating efficiently.
- Prevent failures.
- Increase the equipment life.



It is advisable to maintain a record book for the unit which details all operations performed on the unit as this will facilitate troubleshooting. (see chapter 6.9)



Maintenance must be performed in compliance with all requirements of the previous paragraphs.



Use appropriate personal protective equipment required by current legislation.



WARNING: before any operation, turn off the main power switch.
Only the safety devices check should be done with power main supply.

6.1 Safety system

Essential safety requirements, as recommended by EU Directives, which this unit complies with, must be verified at least every 90 days.

Verification must ensure full operation of all safety devices installed and their reliability. To properly accomplish this duty, the following procedure should be considered:

1. take full note of all safety systems installed on the unit, by carefully examining the technical literature supplied with the unit;
2. with the unit in operation and using all due precautions, create emergency situations and cause safety systems to intervene; verify that in such cases unit is immediately shut off (as an example, emergency situations can be created by opening one by one all inspection doors); repeat test for 2-3 non consecutive times and for the whole series of safety devices;
3. when internal lighting is installed, check that light turns on at safety intervention.
(i.e. at doors opening in the previous example);
4. check correct positioning of all static (or passive) safety devices and that they are steadily fasten to the unit parts; in particular, protection of moving parts must be stable and should be possible to disassemble them only by using special tools.



Once the verification has been completed every 90 days, the documentation must be kept by the operator of the unit, with the result of the checks.

6.2 Fans EC Brushless

6.2.1 Fans maintenance

This paragraph only intends to describe the maintenance / ordinary cleaning of EC Brushless fans. Disassembly of the product must be performed or supervised by qualified personnel with the appropriate technical knowledge. The product is to be disassembled into suitable components for disposal employing standard procedures for motors.



In case of anomalies or malfunctions of the fan, do NOT carry out any repairs. Contact our after-sales assistance that will indicate the most appropriate solution for repair or replacement.



CAUTION !

Terminals and connections have voltage even with a unit that is shut off, danger of electric shock. Wait a few minutes after disconnecting the voltage at all poles before opening the device.



RISK OF INJURY

- Keep out of the device hazard zone;
- When working on the device, switch off the mains power and ensure that it cannot be switched back on;
- Wait until the device stops;
- After working on the device, remove any tools used or other objects from the device.



If the device remains out of use for over four months, we recommend switching the device on for at least three hours at full speed to allow any condensate to evaporate and to move the bearings.

6.2.2 Cleaning and safety test



- Do not use a high-pressure cleaner to clean the device;
- Do not use any acid, alkali or solvent-based cleaning agents;
- Do not use any pointed or sharp-edged objects for cleaning.

What has to be tested ?	How to test ?	Frequency	Which measure ?
Check the device for damage to blades and housing	Visual inspection	At least every 6 months	Replacement of the device
Mounting the connection lines	Visual inspection	At least every 6 months	Fasten the cables
Check the insulation of the wires for damage	Visual inspection	At least every 6 months	Replace wires
Impeller for wear/deposits/corrosion and damage	Visual inspection	At least every 6 months	Clean impeller or replacement of the device
Tightness of screwed cable gland	Visual inspection	At least every 6 months	Retighten, replace if damaged
Condensate discharge holes for clogging, as necessary	Visual inspection	At least every 6 months	Open bore holes
Abnormal bearing noise	Acoustic	At least every 6 months	Replacement of the device
Vibration test	Vibration tester	Recommended every 6 months	Clean impeller or replacement of the device

6.3 Air filters

- a) As filter life depends on ambient conditions in which they operate, it is important to check every 15 days for their status to ascertain chances to reach their standard maintenance schedules.
- b) Every 60 days cleaning or replacement of filters is necessary; if filters are of the cleanable type they can be cleaned either by applying a vacuum to their surface or by washing with lukewarm water and detergent; bag type and absolute filters are not cleanable and must be fully replaced.
- c) When a differential pressostat is mounted, filters cells must be cleaned or replaced when pressure drop reaches the maximum value recommended by the filter manufacturer (usually 200 Pa or 20 mm w.g. for corrugated filters, 300 Pa or 30 mm for bag type filters and 500 Pa or 50 mm for absolute filters).
- d) Roll-type media should be replaced once completely unrolled.



Special attention should be paid for the lack of filter cleaning or replacement can cause a decrease in the unit efficiency because:

- air volume will decrease due to pressure drop increase;
- unit treatment performance will decrease and consequently lower confort will be obtained;
- refrigeration system can be damaged in case of DX coil application.

6.4 Coils

When cleaning or replacing air filters, check for status and cleanliness of coil fin packs. Lack of or late filter maintenance can impair filters and consequently allow dirt and foreign matters to clog coil fin packs.

In this case do not use any cleaning system that may damage the fins, but use compressed air in counterflow to the normal air direction. In case of deformations, fins can be restored by using a suitable calibrated fin comb.

When coils are seriously damaged and must be disassembled, proceed as follows:

1. ascertain that external available space is sufficient for the complete coil withdrawal, as prescribed in paragraph 4.2;
2. shut off inlet and outlet valves and drain coil by opening vent and discharge;
3. disconnect coil headers from water circuit;
4. take out headers cover panel and, inside unit, the side metal sheet protections;
5. by lifting headers end slide coil out on its guide rails, possibly greased if necessary;
6. in case unit must continue to operate without the coil, reassemble header cover panel and close connection holes.

To install the repaired coil, proceed in the reverse order with the above operations, if necessary lubricate the guide with grease and make sure the headers are sealed on the panel.



All of the operations described in this chapter **MUST BE PERFORMED BY TRAINED PERSONNEL ONLY.**

Before commencing service work on the unit ensure that the electric supply is disconnected.

Care must be taken when working in surroundings of coils.

Aluminium coil fins are very sharp and can cause serious wounds. After servicing, replace the cover panels, fixing them with locking screws.

6.5 Dampers

Every 180 days check that dampers complete their full movement freely and without stops, particularly the motorized ones.

For manually controlled dampers, check the holding device that keeps them in position.

6.6 Unit shut down precautions

When unit is expected to be idle for long periods, it is recommended to use the following simple precautions:

1. disconnect power supply on the general electric panel and place a warning notice that unit is idle;
2. shut off water supply;
3. empty unit sumps;
4. shut off coil valves and drain coils;
5. shut all dampers off;
6. if unit is equipped with absolute filters, take them out and store in sealed boxes;
7. every 30 days have fan to rotate for few seconds to avoid damages to bearing of the impeller.

In case unit could remain idle at ambient temperature below 0° C, it is particularly important to proceed to coil drainage; furthermore it is necessary to empty all siphons to prevent frost breakage. If the water circuits of the coils are not emptied, is necessary filled them with an anti-freeze solution as illustrated on the table in paragraph 5.5.

In case of stops for long periods (years) the anti-freeze solution may not be sufficient due to the separation of glycol from water, therefore it is recommended to empty the battery circuits.

6.7 Summary schedule for periodical maintenance

	15 days	30 days	60 days	90 days	180 days	12 months
Security systems (check and test)				*		
Motors / fans						
- bearing, eventual lubrication						*
Air filters						
- check	*					
- cleaning or replacement			*			
Coils (check)			*			
Dampers (check)					*	

“Check and tests” of safety systems must be recorded with all other maintenance interventions in the “Unit record book”. A sample of this manual is shown at point 6.9.

All maintenance periods refer to unit effective operation days with a continuous service of 12 hour/day. For operational periods longer of shorter than indicated, maintenance schedule must be adjusted accordingly.



“Check and tests” of all safety systems and bearing greasing must be accomplished in any case every 12 months, even if unit is operating for limited periods only.

6.8 Trouble shooting

	Trouble	Possible Cause	How to solve
1.	Active safety fails to operate	Electric system failure Electric components failure	Call electric maintenance Replace component or call our Service
2.	Insufficient air volume	Dirty filters Dirty fin pack Wrong fan rotation Ecessive pressure drop Dampers shut off	Clean or replace filters Clean coils Change electric motor connections Check system design / Call for fan section modification Open dampers and check their control
3.	Ecessive air volume	System pressure drop lower than forecasted Components missing (for example filters?) Inspection panels open	Check dampers Check system design Call for fan drive modification Check inside unit and install missing elements Shut panels off
4.	Low thermal capacity	Insufficient air volume Lack or insufficient supply to coils Coil connections inverted Fin pack dirty or battered Air bubbles in circuit, on liquid coils Fluid exchange temperatures not at design values	See trouble 2 Open shut off valves Check pump rotation and, if wrong, change pump electric connections Check pump flow Invert inlet/outlet connections Clean and comb fin pack Purge coils Check thermostats on thermal sources (boilers or chillers)
5.	Droplets carryover	Ecessive air volume	See trouble 3
6.	Excessive noise and /or vibrations	Warn bearings on fan Rotating parts out of balance Foreign matters in rotating parts Fan safety guard not tighten Panels fixing screws untighten One phase out on motor power supply Incorrect power main supply	Replace bearings Balance or replace rotating parts Clean internal part Tighten fixing screws Carefully and smoothly tighten screws Check terminals and tighten bolts Check power supply comparing with electric characteristic on name plate

7. UNIT CLEANING

The table below gives some advice on the use of suitable or unsuitable products for cleaning and maintenance of stainless steel products.

Cleaning product	Use	Advice
Freshwater	YES	If rich of limescale can lead to appearance of stains on the surface. Dry thoroughly.
Deionised water	YES	Indicated, as it avoids the appearance of stains on the surface, compared to normal water.
Neutral cleanser / degreasers	YES	Important to rinse thoroughly.
Cleansing powder or abrasive detergents	ATTENTION	They can damage the appearance of the surface finish.
Muriatic acid Solutions based on hydrochloric acid Bleach Halides Silver cleaning products	NO	If they accidentally come into contact with the material, it is important to ensure short contact times, rinse thoroughly and pay close attention to cleaning to the interstitial areas of stagnation.
Clean cloth Nylon sponge	YES	Make sure that there are no particles that could scratch the surface.
Inox scourer	ATTENTION	It does not contaminate the surface, but can damage its appearance.
Non-Inox scourer	NO	Iron contamination problems.

For the sake of completeness, the table below lists some of the most common problems that may occur on the component and the remedies to be followed to restore the situation.

Problem	Description	Solution
Iron contamination	Iron particles that may be trapped on the surface of the stainless steel product directly, such as the use of brushes or flakes with non-stainless steel wire, or indirectly, such as grinding performed on a common steel component placed near the stainless steel part. The iron particle in contact with the stainless steel will oxidize very quickly (rust) causing an unsightly staining of the surface, which in some cases may evolve into localized corrosion phenomena.	If the phenomenon is in the initial phase, it is possible to intervene with simple washes, possibly using nylon sponges. If, on the other hand, the phenomenon is more pronounced, especially in cases where the surface already shows signs of localised corrosive ignition (pitting), it is necessary to consult an expert on the surface treatments of stainless steel.
Generical contamination	This is the trapping of non-ferrous particles rather than stubborn dirt, glue residues or other exogenous materials.	In the case of contamination with other metals such as aluminium, copper, etc., the treatment methods are the same as for ferrous contamination. In case of glue residues or persistent dirt, degreasers or solvents such as acetone etc. may be used. An abundant rinsing after use is essential. If, on the other hand, the contamination has progressed to localised corrosion of the material, then it is necessary to proceed in consultation with an expert as described in the previous point.
Surface scratches	Accidental engravings on the surface of the stainless steel.	If you are sure that no ferrous contamination has occurred (a tool that has previously worked on common steels) you can apply a special detergent / polish for stainless steel, using a soft cloth.
Oil and grease residues	Accidental splashing or fingerprints.	These can be eliminated with the use of alcoholbased products, both denatured and isopropyl, or with acetone. The application can be done with a soft cloth, so as not to scratch the surface, then it is advisable to rinse with water.
Paints or graffiti	Accidental splashing, vandalism.	To eliminate these superficial marks, specific products must be used, generally alkaline or solvent stripping products and then carefully wash, preferably with hot water (60°C). Mechanical removal should be avoided, e.g. by means of scrapers or knives, which would straighten the surface.
Cement, mortar, chalk	Accidental splashing or traces	They can be removed with water with a low percentage of phosphoric acid in solution. Afterwards, rinse thoroughly with water and then dry.

8. REPLACEMENT PARTS

8.1 Unit identification

AHU model is univoquely identified by the "Type" and "Series" indicated on the name plate, (Fig. 1) normally located on the external surface of the inspection panel of the fan section.

Same identification data are indicated at Chapter 1 – "Unit identification", on the "TECHNICAL SCHEDULE" and on the "GUARANTEE CERTIFICATE".

8.2 Identification of the part to be replaced

Once ascertained the component to be replaced, for normal wearing out or for any falts, refer to the "TECHNICAL SCHEDULE" and identify its correct type and description in order to place a correct and clear order.

8.3 Replacement parts ordering

Order should be placed by fax or e-mail at info@vorticeindustrial.com, with clear indication of:

- type and serial number as indicated at point 8.1
- type and full description of the parts requested as indicated at point 8.2
- quantity (number of pieces) requested for each item.



The Company will inform on price and delivery of parts by return.
It is recommended that only original replacement parts be used, of same type and Quality as selected at unit design; this will guarantee unit performance and reliability.

9. DISMANTLEMENT, MATERIALS' DISPOSAL AND RECYCLING

9.1 Unit disconnection

Disconnection operations must be effected by a qualified technician, who must follow the dispositions provided in this manual into the section "residual risks".

Before the disconnection of the unit the following materials (if any) must be recovered:

- refrigerant gas, when it is impossible to isolate circuits, for direct expansion coil units. The extraction of refrigerant gas must be effected with intake devices, which operate in a closed circuit to assure that no material will be released in the atmosphere
- Antifreeze fluid into the circuits: during its removal it is important to avoid any losses into the environment. Antifreeze fluid must be stored into appropriate container, as provided by the laws in force.



Awaiting dismantlement and disposal moment, the unit can be stored even outdoor, because bad weather and sudden changes in temperature cannot cause damages for the environment.



During recovery operations it is important to pay a great attention to avoid damages to people or environmental pollution.



During dismantlement phase the fan, the coil, the motor (if they are still usable) can be recovered in specialized centres.



The antifreeze liquid must be stored in appropriate containers according to the law.



Recover and dispose of materials according to national laws in force.

The structure and the various components, if not usable, must be demolished and subdivided according to their nature; in particular steel and aluminum present in high quantities in the unit.

All materials must be recovered or disposed of in compliance with the relevant national law.

- In the following table you can find the materials employed to build the unit, even those which are present in its components:

Material type	Employment	Q.ty in relation to weight	Presence
Rolled metal	baseframe - panels fan - electric motor	HIGH	ALWAYS
Aluminium	case - electric motor's structure - coils dampers - droplet separators	HIGH	ALWAYS
Copper	coils - motor	MEDIUM	ALWAYS
Polyurethane	panels	HIGH	OPTIONAL
Mineral wood	panels - sound attenuators	HIGH	OPTIONAL
Gummy material	gaskets - rubber shock absorber antivibration joints	LOW	ALWAYS
Nylon	handles - hinges - claps panelblocks	LOW	ALWAYS

In order to better assist its customers and users of its equipment, the Company will be obliged if any changes in unit property are communicated by simply giving:

- serial number or construction number of the unit;
- new user's name and address;
- new unit location in case of change in installation address.

9.2 RAEE Directive (only UE)



- The RAEE Directive requires that the disposal and recycling of electrical and electronic equipment must be handled through a special collection, in appropriate centers, separate from that used for the disposal of mixed urban waste.
- The user has the obligation not to dispose of the equipment at the end of the useful life as municipal waste, but to send it to a special collection center.
- The units covered by the RAEE Directive are marked with the symbol shown above.
- Additional information can be obtained from the manufacturer.

A duplicate of this manual can be requested in case of damage or loss.

10. Indicative positioning of adhesive signaling and name plate of identification

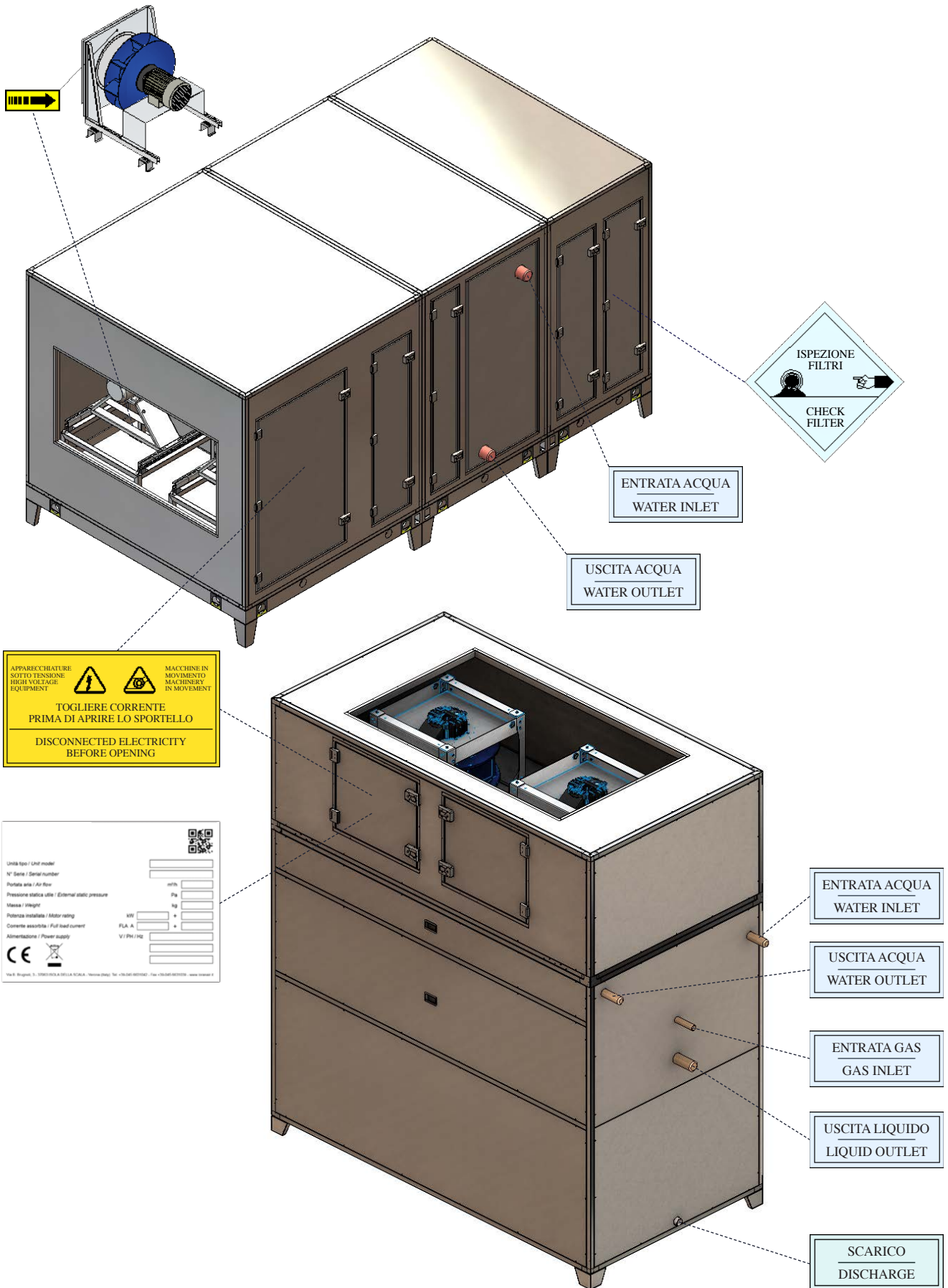



VORTICE INDUSTRIAL S.r.l. si riserva il diritto di apportare tutte le varianti migliorative ai prodotti in corso di vendita.
VORTICE INDUSTRIAL S.r.l. reserves the right to make improvements to products at any time and without prior notice.
VORTICE INDUSTRIAL S.r.l. se réserve le droit d'apporter toutes les variations afin d'améliorer ses produits en cours de commercialisation.
VORTICE INDUSTRIAL S.r.l. behält sich vor, alle eventuellen Verbesserungsänderungen an den Produkten des Verkaufsangebots vorzunehmen.
VORTICE INDUSTRIAL S.r.l. se reserva el derecho a hacer cambios en los productos para su mejora en cualquier momento sin previo aviso.
VORTICE INDUSTRIAL S.r.l. 公司 股份有限公司 保留在产品销售期间进行产品改良的权利。

VORTICE GROUP COMPANIES

VORTICE S.p.A.
Strada Cerca, 2- frazione di Zoate
20067- Tribiano (MI)
Tel. +39 02-90.69.91
ITALY
vortice.com
postvendita@vortice-italy.com

VORTICE INDUSTRIAL S.r.l.
Via B. Brugnoli, 3
37063- Isola della Scala (VR)
Tel. +39 045 6631042
ITALY
vorticeindustrial.com
info@vorticeindustrial.com

VORTICE VENTILATION SYSTEM (CHANGZHOU) CO.LTD
Building 19, No.388 West Huanghe Road, Xinbei District,
Changzhou, Jiangsu Province CAP:213000
CHINA
vortice-china.com
vortice@vortice-china.com

VORTICE LIMITED
Beeches House-Eastern Avenue
Burton on Trent- DE 13 0BB
Tel. +44 1283-49.29.49
UNITED KINGDOM
vortice.ltd.uk
sales@vortice.ltd.uk

VORTICE LATAM S.A.
Bodega #6
Zona Franca Este Alajuela- Alajuela 20101
Tel. (+506) 2201 6934
COSTA RICA
vortice-latam.com
info@vortice-latam.com

CASALS VENTILACIÓN INDUSTRIAL IND., S.L.
Ctra. Camprodon, s/n
17860- Sant Joan de les Abadesses (Girona)
SPAIN
casals.com
ventilacion@casals.com